

SPEEDWAY SEDANS QUEENSLAND INC

SSQ NOSTALGIA SEDAN

SPECIFICATION MANUAL RULES & REGULATIONS

July 2024 – Online Version 4



Speedway Sedans Queensland

Enquiries to State Technical Representative or
Email: statetech@qsca.com.au

Website – www.qsca.com.au

Section	TABLE OF CONTENTS	Page
1	Interpretation	3
2	General	3
3	Authority to Exclude	3
4	Racing Rules	3
5	Daylighting / Registration / Race-Practice Day	3
6	Declaration of Compliance	4
7	Inspection	4
8	Construction	5
9	Minimum Specifications	5
10	Definitions	5
11	Penalties	5
12	Driver Safety	5
13	Protective Clothing	5
14	Seat Belt	6
15	Installation of driver restraint systems	6
16	Interior rear vision mirror	8
17	Window Net	8
18	Padding	9
19	Seats	9
20	Type of sedans that can be used	9
21	Body	9
22	Roll cage specifications	10
23	Bumper Bars	13
24	Skid Rails	14
25	Reinforcing	14
26	Engines	14
27	Carburetor	14
28	Cooling System	15
29	Exhaust System	15
30	Transmission / Driveline	15
31	Battery and electrical system	16
32	Steering	16
33	Brakes	16
34	Suspension	16
35	Front/rear hubs, axles, and tail shaft	16
36	Fuel	17
37	Replacement fuel tank and fuel system	17
38	Fuel lines and fittings	17
39	Wheels and Tyres	18
40	Identification Numbers	18
41	Paint work and sign writing	18

SPEEDWAY SEDANS QUEENSLAND SSQ NOSTALGIA SPEEDWAY SEDAN

SPECIFICATIONS

1. INTERPRETATION

Speedway Sedans Queensland shall be the sole authority for the interpretation of specifications as contained in this book with circularized amendments. At any race meeting this authority is delegated to the Head Technical person.

2. GENERAL

Nostalgia Sedans are a Queensland state class and as such are not able to race outside of the state of Queensland. Speedway Sedans Queensland acknowledge that Nostalgia Speedway Sedans have been built/restored primarily for the owner's pure pleasure of owning one and with the intention of running club days, demonstrations for promoters, static displays, car shows, street parades, festivals, and speedway racing.

During competition Nostalgia Sedans are NOT permitted to carry a Passenger. (01/07/24)

All Nostalgia Sedans MUST comply fully with these specifications by no later than 1st January 2025.

Specifications listed in this book are of a general nature only. **IF "IT" is not in the book,** enquire for prior clarification or approval. Speedway Sedans Queensland are responsible for the introduction of any specification changes/upgrades.

Cars must always be well presented. Race tape and zip ties are only acceptable for repairs on race days.

BEFORE CONSTRUCTING RACE CAR, READ THE SPECIFICATIONS CAREFULLY.

It is better to ask first than be required to change something after the car has been constructed.

Drivers and crews will always abide by the Speedway Australia, Speedway Sedans Australia and Speedway Sedans Queensland Codes of Conduct.

All drivers must be the holder of a senior SSA Speedway Australia competition licence applicable to the SSQ Nostalgia Sedan class. Licence must be noted accordingly.

3. AUTHORITY TO EXCLUDE

If there is a dispute as to compliance of any car at any time Speedway Sedans Queensland will adjudicate. Cars outside the specification will be unable to compete until such time as compliance has been achieved.

Only items of non-safety and/or non-performance will be given a 7-day work order.

4. RACING RULES

SSQ Nostalgia Sedans is a NON-CONTACT speedway racing division. All care must be taken to avoid contact with other competitors.

Speedway Racing will be conducted under the Speedway Australia Racing Rules and Regulations – current at time of event being held.

5. DAYLIGHTING / REGISTRATION / RACE-PRACTICE DAY (07/23)

Each car will be required to apply for and obtain registration and be issued with a Logbook and registration decal for each racing season. Cars are registered July through to June each year. To accommodate the northern season, registration is available from 1 May each year and will carry forward to the next season.

Each car must be inspected at times as directed by Speedway Sedans Queensland.

For cars that had a daylight inspection completed in the 2022/2023 season and were registered for the 2022/2023 season; these cars are permitted to re-submit this daylight inspection for registration purposes for a further two registration periods.

To continue to use the 2022/2023 daylight inspection sheet the car must be continually registered. If the car is not registered for one or more years, it will be required to have a daylight inspection completed for re-registration purposes.

Cars not registered in the 2022/2023 season are required to have a daylight inspection completed for 2023/2024 season or any other subsequent season in the future.

Complete online Application to Register Race Car - <https://www.qsca.com.au/car-registration/>

Payment options are included in the confirmation email received after completing the online car registration form.

Definition of a new car – A new body shell is deemed to be a new car requiring a new registration.

PRACTICE AND/OR RACE DAY INSPECTION

- a) The logbook must be endorsed by an SSA Inc registered machine examiner/scrutineer at each practice or race meeting prior to entering the track. A logbook without endorsement by the SSA Inc Machine Examiner/scrutineer is equivalent of a no participation ticket.
- b) Race Day scrutineering – a competitor/owner of a car taking part in the practice or race meeting must not scrutineer or sign off the logbook for his/her own race car.
- c) Race Day Work Orders – Maximum work order at ANY race meeting, either Club or State to be 7 days or next participation in competition – whichever comes first. 7 Day work orders to be issued only for non-safety and non-performance items.
- d) A current copy of the Daylight Sheet to be stapled into the back of the logbook.

6. DECLARATION OF COMPLIANCE

DECLARATION OF COMPLIANCE will cover eligibility for class and ALL points of SAFETY including material specification and sizes. Details of the declaration are to be placed in the logbook.

REGISTRATION IS NOT COMPLETE UNTIL pages 2-5 of the logbook are completed and signed by the owner/driver and the Scrutineer/technical representative.

A current season Decal as supplied with Logbook must be affixed to car.

7. INSPECTION

Cars must pass a pre-registration examination to receive logbook endorsement. The Scrutineer can revoke this endorsement any time if the vehicle is found defective. The endorsement may be withdrawn until repair or adjustment has been made and approved.

Driver and/or owner to be present at the time of inspection.

Drivers are responsible for having the logbook endorsed before an official practice session or meeting.

An unendorsed logbook is a NO RACE/PRACTICE TICKET.

Structural or other specification changes to the registered car made during the season MUST be officially notified and car re-inspected before taking further part in competition.

8. CONSTRUCTION

To be of a professional standard using first grade materials – no downgrade material allowed. All materials quoted are minimum sizes unless a maximum is specifically quoted.

9. MINIMUM SPECIFICATION

The roll cage is to prevent the collapse of cabin area under impact, all bar work must be entirely inside the OEM glassed area of the cabin.

Roll cage, to enclose the driver, to be full width and full height of the cabin area. The roll bars are to constitute a cage type framework, braced fore and aft. The cage must extend from behind driver's seat forward to the windscreen area and incorporate protection for the driver's feet.

All roll bar material must be of good quality mild steel, AS1450, minimum Gr300. MINIMUM 38mm O.D. x 3.0mm w.t. CHS. (Sonic test at not less than 2.70mm ABSOLUTE). Aluminium based materials not permitted.

All bends to be made using a pipe bender with the correct size former, with no evidence of crimping, wall failure, or significant weakening. Galvanised tubing or welding over threaded tubing is not permitted in any structural bar work.

Water pipe fittings or malleable fittings are not permitted. Roll cages built using other than fusion welding techniques will not be accepted. Gussets on welded joints may be required at daylight inspection/or any subsequent inspections.

10. DEFINITIONS

ERW – Electric Resistance Welded

CDS – Cold Drawn Seamless

C.H.S. = CIRCULAR HOLLOW SECTION

R.H.S. = RECTANGULAR HOLLOW SECTION

W.T. = WALL THICKNESS

OEM – Original Equipment Manufacturer; used to indicate parts used, or the complete vehicle as it left the production line from the original manufacturer and means for make and model unless otherwise stated.

PROPRIETARY – (of a product) – marketed under and protected by a registered trade name.

11. PENALTIES

A penalty will apply to:

- i. Any person who is guilty of misrepresenting a race car or safety attire/equipment or having a non-compliant engine or making a false Logbook declaration.
- ii. Any person who knowingly provides wrong information for the Registration of a race car.

12. DRIVER SAFETY

All protective clothing and safety equipment must be used and/or worn in the approved and accepted manner.

All race wear/equipment to be inspected at each practice/race meeting.

Mandatory from 01.07.24 – a HANS Device neck restraint with approved helmet attachments must be used.

Note from 01.07.24 AS/NZ1698 helmets are not permitted to be used.

13. PROTECTIVE CLOTHING

All protective clothing must comply with minimum standards for Safety Apparel as specified in the current Speedway Australia Racing Rules and Regulations and/or notices issued by the SSQ Inc from time to time for safety standards pertaining to SSQ Nostalgia Sedans.

14. SEAT BELT – Five or Six-point restraints are mandatory. Seat belt to be lever latch type. An approved type racing harness must be fitted, using a minimum of four major belts and four mounting points plus one or two anti-submarine/crotch straps. Anchor bolts to be 10mm STEEL min. Minimum rating SFI 16.1.

The seat belt must be no older than 2 years from the date of manufacture or not older than the expiry date indicated on the seat belt. An unmarked seat belt is deemed to be non-compliant.

15. INSTALLATION OF DRIVER RESTRAINT SYSTEMS

For the driver restraint system to be fully effective, considerable thought must be given to the location of mounting points and to proper installation.

With the seat, roll cage and belt anchors all part of the same structure; deformation of the remainder of the car does not put driver at serious risk.

The mounting points must be solid and should remain so, even if the vehicle is deformed due to an accident. The mounting points should also not put undue strain or twist on the belt system hardware.

The lap belt should be positioned so it rides across the solid pelvic area and not the soft stomach area or down on the thighs. The shock absorbing ability of the pelvic area and its ability to protect internal organs make it the preferred location for the lap belt. See Fig (1) and (2A).

The shoulder harness should be mounted to prevent driver's shoulders from moving forward (upwards if semi-reclining), out of the seat, in the event of a rollover. The required minimum 51mm (2") from the top of the driver's helmet to the HEAD PLATE does not leave much leeway for the shoulder harness to prevent the helmet from striking the head plate or bar work in the event of a rollover. The shoulder harness is a major means of preventing injury in such an incident.

Anti-submarine straps serve two purposes.

- i. To secure the lap strap down across the driver's hips, so in the event of an accident, it is not pulled up across the stomach by the shoulder straps.
- ii. To prevent the driver from sliding forward and out of the harness. When the driver is seated in an upright position, as in most sedans, a five-point system (a single anti-submarine or crotch strap) is considered adequate (Fig.1). For extra assurance a double strap anti-submarine belt can be used (Fig. 2A).

When the driver is seated in a semi-reclining position, a six-point system (two anti-submarine or crotch straps) is preferable. Most drivers find the two anti-submarine straps system more comfortable.

Typically, the anti-submarine straps are mounted much too far forward of the seat. This practice could cause unnecessary injury as the body can slide partially out of the seat before being restrained when the strap contacts the groin. It is much more practical to cut a slot in the seat bottom so the anti-submarine strap can be anchored in line with the chest.

Because of the differences (often vast) in competition vehicles, a "standard" method of mounting is impractical. Good judgment and common sense in inspecting restraint system mounts is needed.

Safety equipment is often neglected in favor of performance equipment, but its proper operation when the need arises is essential to survival.

Shoulder belts are to have separate anchor points/adjusters. (Fig.2).

Seat back support/shoulder belt mounting bar – 38mm x 3mm CHS Minimum.
Seat belt mounting brackets (anchor points) must be on roll cage and sub frame or substantial bar work (e.g., 38mm x 3mm CHS) not mounted on sheet metal.

ADJUSTMENT OF DRIVER RESTRAINTS

With the driver fully kitted out in race underwear and driving suit, check that, with the driver seated, belt slots in the seat line up with natural line of the belt from anchor to buckle when just the lap belt is tensioned. Ensure that the lap adjusters do not foul the seat and that they are readily accessible. Some belts adjust by pressure downwards, others by pull up. Check that the driver can manipulate belt adjusters with gloves ON. Check also that anchor hardware is aligned and that it is not possible to have a hitch in the anchor area without detection (sudden release of the belts to 50mm slack can put the driver off-line). Now check if the belt is holding the seat or the driver: it should be the latter.

Adjust the anti-submarine strap/s to ensure that the buckle is held flat and close to the body over the pelvis.

When satisfied that the lap belt is OK, put on the helmet and check just how far the helmet (with visor) can reach, head plate clearance, window net etc.

Slacken the seat belt, engage the shoulder belts into the buckle and tension the seat belts again checking position of buckle and adjusters. Tension each shoulder belt, checking that the adjustment range is suitable to the driver, that the belts and hardware don't foul the seat and that the natural line of the belts holds the driver as with the lap belts. Also note any change in the buckle location and lay. If there is too much variation with buckle it would appear that lap anchors are not in optimum position.

Before the driver releases the buckle, he/she should slacken shoulder belts with the adjusters, keeping the area of the adjuster supple, accessible for cleaning and making entry/exit to the car a simple routine.

While lining up for restarts, it becomes a simple exercise to tug the adjusters to snug up the belts and stay in control of the car.

INSTALLATION OF DRIVER RESTRAINT SYSTEMS

CROTCH STRAP SHOULD BE ANCHORED
IN LINE WITH THE CHEST

THE SEAT BELT ANCHOR SHOULD BE 2 ½
INCHES FORWARD OF THE BACK LINE OF
THE DRIVER



5 POINT SYSTEM

SEAT BELTS SHOULD BE ANCHORED APART THE SAME
DISTANCE AS THE DRIVER IS WIDE. MOUNTING
BRACKETS SHOULD BE ANGLED THE SAME DIRECTION
AS BELT PULL AND NOT TILTED IN OR OUT

(2)

ROLL BAR MOUNTED
SHOULDER HARNESS

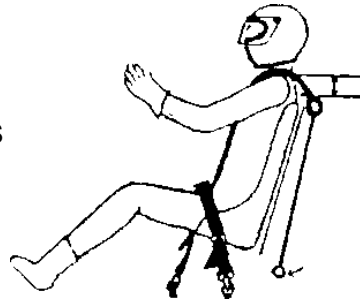

BELTS ANCHORED 4"
BELOW SHOULDER LINE

SEAT BELT
MOUNTING
POINT

SHOULDER HARNESS SHOULD BE ANCHORED AT A 45 DEGREE
ANGLE FROM THE SEAT. IF MOUNTED TO A ROLL BAR CROSS
BRACE LOCATED 4 INCHES BELOW THE SHOULDER LINE

6 POINT SYSTEM

(2A)

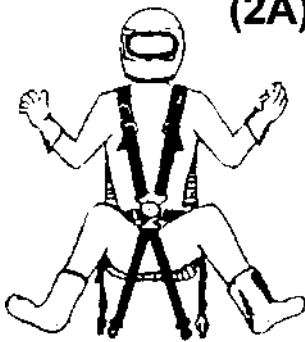

CROTCH STRAP MOUNTS AS FAR APART AS COMFORTABLE

16. INTERIOR REAR VISION MIRROR

- a) An interior rear vision mirror is NOT permitted.

17. WINDOW NET is MANDATORY

- a) Window net to be in good condition
- b) Window net to be minimum approved SFI standard 27.1
- c) Window nets with SFI rating that have manufacture dates be replaced every two years.
- d) Window nets with SFI rating that have an expiry date be enforced and replaced according to expiry date.
- e) As from 01/07/.2023 SFI rated window nets with expiry/end date are mandatory.
- f) Window net minimum rod thickness 6mm.
- g) The window net must be hinged from the bottom and must be fixed/fastened at the top via a 6mm rod threaded through the cavity provided. The rod must be secured with lock pins or a central spring-loaded pin.
- h) Window net must be secured to the roof hoop bar and top NASCAR door bar. Quick release seat belt type attachments are also permitted.
- i) Window net must be entirely removable without the use of tools in the event of an accident.

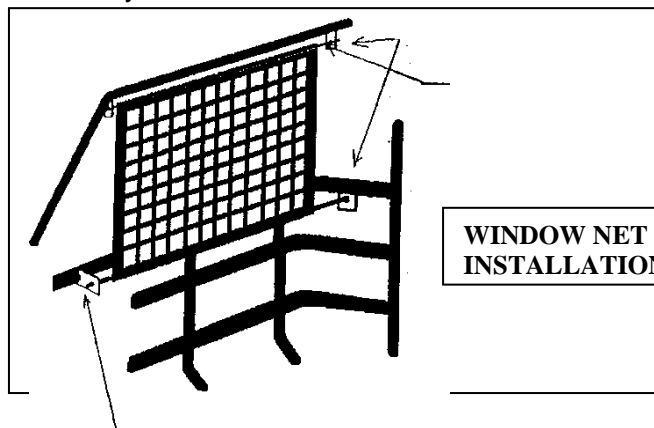

**WINDOW NET RECOMMENDED
INSTALLATION**

18. PADDING

The driver must be protected, in the racing car, from all sharp edges and projections or bar work that could cause injury in an accident. Padding that is required on bar work, will be if the helmet of the driver is within 75mm of bar work while fully restrained in the race seat. Please bear in mind the non-use of flammable padding is required.

19. SEATS – DRIVER SAFETY

Note - Full containment type seats must be fitted with head, shoulder, and hip support no later than 1st July 2022.

- a) Approved proprietary line competition seats and mounts permitted e.g., Kirkey/Butler which are to be installed as per manufacturer's specification. **Must be mounted fully in front of the main roll cage hoop.**
- b) Seat to be mounted with 4 bolts in the base and 2 in the back. Seat base is determined to be lower sides in hip area and base.
- c) Concave seat to fully support back area to a minimum of shoulder width.
- d) Head rest to be 150mm wide at point of contact with helmet and may be padded up to 50mm thick Max. Resilient material. The driver's head rests must be securely mounted to the roll cage.
- e) Front of seat under legs to be raised and rolled.
- f) Cut-outs for belts to be suitably grommeted.
- g) Seats may be padded and covered 50mm maximum. Dominator Seats are deemed to be covered seats and do not require any further covering.
- h) Spring upholstered or magnesium alloy seats are not permitted.
- i) Seat base to be mounted by four 8mm bolts with minimum 30mm washers to minimum 25x25x3mm RHS or 25mmx3mm C.H.S. frame, attached securely to roll cage.
- j) Seat back to be bolted (with minimum two 8mm bolts) to a brace attached to roll cage approx. 75mm below shoulder height.
- k) A full containment seat must be mounted as per manufacturer's specifications – if it cannot be mounted as described above it cannot be used.

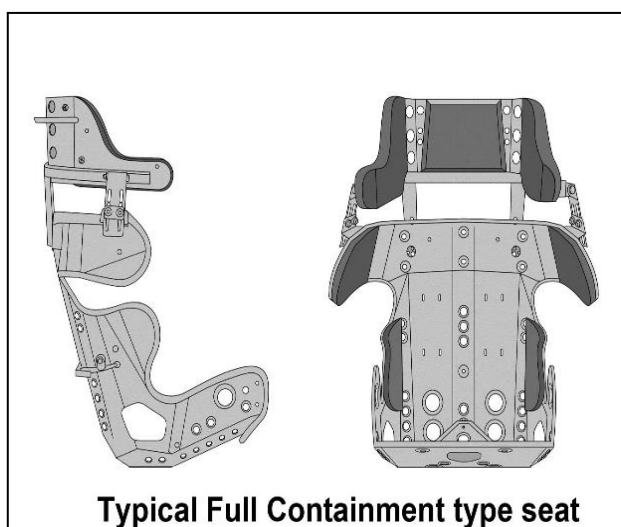

20. TYPE OF SEDANS THAT CAN BE USED

Cars must have been manufactured more than 50 years ago. Example – in 2021 no car manufactured later than 1971 is permitted. **As of 1 July 2023, the introduction of further makes/models post 1973 has been suspended until further notice.**

Cars must have been catalogued for general sale in Australia – no special import vehicles permitted.

Utes, wagons, and Convertibles NOT permitted.

No V8 engines permitted.

21. BODY

All vehicles are to be kept in good repair so a better image can be projected to the paying public and to prospective sponsors.

PARTS TO BE REMOVED FROM BODY

- a) Bull bars.
- b) Original fuel tank
- c) Original bench or sprung bucket seats
- d) All glass interior trims.
- e) Door handles

f) Ornamentation

Glass window openings must not be covered with fibreglass or other material.

MODIFICATIONS TO BODY

- a) Race car is to use an original, complete metal body.
- b) Inner panels in the cabin area may have minor modifications to allow roll cage to be fitted.
- c) Original dash panel may be removed, if removed must be replaced with full width metal fabricated panel.
- d) Front firewall to have holes covered with steel/metal securely attached to firewall. 1.6mm MAX. Engine bay to be fully sealed from cabin area.
- e) A rear metal firewall must be fitted to isolate the driver from the boot area. The manufacturer's rear parcel tray or equivalent must be welded to the body in the original position and the firewall mounted to the front section of the parcel tray in the original plane. If a vehicle is used where a firewall was not fitted as standard the fuel tank must be fully isolated from the driver using metal of 1.0mm minimum. No other sheeting permitted inside the car.
- f) Wheel arches – may be cut out to give a minimum of 50mm clearance around tyres. The inner and the outer panels of the wheel arch are to be re-welded together. However, where possible, to be left standard in appearance.
- g) All panels are to be securely attached to the body. Front nose cone may be fabricated out of body metal or fibreglass to original shape.
- h) If the original grille cannot be used a substitute grille can be fitted retaining the original appearance as close as possible.
- i) Headlight and Taillight openings to be covered, with maximum 1.6mm material.
- j) Fibreglass or other approved material panels can be used as a replacement for any or all removable steel panels. To keep the cars in a presentable condition, removable fibreglass panels may be used over non-removable original steel panels. NO OTHER DOUBLE PANELING PERMITTED.
- k) Fibreglass or other approved material panels to be of original shape and mounted securely in the original position. Panels that may be replaced are front guards, bonnet, door skins, and boot lid. The steel roof must be retained. **Rear quarter panels may be removed from the lower edge of the rear window in a line to the rear centre axle line.**
- l) If replica panels used: - to assist with the fitting of door panels, maximum of 25mmx25mm x 3mm RHS, may be welded at windowsill height from A to C pillars.
- m) No self-tapping devices to be used to hold panels to body or anywhere else on the race car.
- n) Bonnet to be securely fastened. Four bonnet pins (five for fibreglass) to be 12mm minimum to 15mm maximum mild steel or approved equivalent.
- o) No mounting pins on the side of panels i.e., mudguards. Bonnet lock pins 3mm min to 6mm max. Heavy duty large reinforcing washers (min 30mm OD) to be fitted to all bonnet pin holes on fibreglass bonnet.
- p) Fibreglass bonnet, if fitted, must have 5 bonnet pins or, if FJ or FX, 4 pins are required.
- q) Hinged bonnet and boot lid permitted, using minimum of two pins. Skeletonising within 50mm of the hinge area is not permitted.
- r) Boot lid to be securely attached in a minimum of 4 points. **If using a fibreglass boot lid** heavy duty large reinforcing washers (min 30mm OD) to be fitted to all boot pin holes on fibreglass boot.
- s) **FJ Holden only** - Left hand front door may be operational provided a bolt is inserted through the top frame of both left-hand doors, at the B pillar with an R clip inserted through the bolt.
- t) **FJ Holden Only** – if left hand door to be operational for driver entry a crucifix is to be placed on the left side of the roll cage between the A pillar front leg and the Main Hoop – to be from window height to roll cage sub frame and be 38mmx3mm CHS. See the drawing above.

- u) B pillars from the windowsill to the turret must remain in the original position to maintain silhouette of the car for presentation. B Pillar below windowsill to doorsill may be removed.
- v) The rear wheel inner guard and rear boot floor permitted to be removed from the rear centre axle line back to the rear of the car – if this constitutes a suspension mounting point – the mounting point must be refabricated in the original position.
- w) Front subframes permitted to be fabricated forward from the front firewall and to constitute all suspension and engine mounting points in original position.
- x) Front and rear fabricated subframes/rails – maximum 50x50x3 RHS and must remain inside original body line.

22. ROLL CAGE SPECIFICATIONS

All cars must be fitted with a complete roll cage.

ROLL CAGE CONSTRUCTION

- a) The roll cage is to prevent the collapse of the cabin area under impact. Roll cage to enclose the driver, to be full width and full height of the cabin area. Pop rivets, Self-drilling (Tek) screws etc., or self-tapping screws are not to be used.
- b) The roll bars are to constitute a cage type framework, braced fore and aft.
- c) The cage must extend from behind the driver's seat forward to the windscreen area and incorporate protection for the driver's feet. All roll cage bar-work is to be inside the body.
- d) All roll bar material must be of a good quality mild steel, minimum AS1163 Gr300 MINIMUM 38mm OD x 3mm wt. CHS. (Sonic tester reading at not less than 2.70mm ABSOLUTE). Aluminum based materials are not permitted.
- e) Allowance to use CDS (Cold Drawn Seamless) for construction of roll cage is permitted. Full material and design option as per the SSA National classes. No mixing and matching of material and design permitted.
- f) All bends to be made using a pipe bender with the correct size former. Galvanized tubing or welding over threaded tubing is not permitted on any structural bar work. Water pipe fittings or malleable fittings are not permitted.
- g) Roll cages built using other than fusion welding techniques will not be accepted. Gussets on welded joints may be required (Daylight Inspection).
- h) The rear main hoop and the main roll cage bars will each be made of one continuous length of tubing, with smooth continuous bends and no evidence of crimping, wall failure or significant weakening. (Fig. 6 (ii)).
- i) For all new registrations after 01.07.23 - Main roll cage hoop to be within 50mm of sides of roof at narrowest point. The top windscreen bar to be within 80m of the windscreen.
- j) Roll cage legs – to be welded to top of a sub-frame of tubular or angle section running fore and aft. The sub-frame is to be securely welded or bolted to the floor pan/sills using at least four 12mm steel bolts through the sub-frame and using 100mmx100mm x 3mm minimum FMS plates under the floor or bolted on the spreader bar no more than 150mm from sub-frame.
- k) To assist in the fitting of roll-cage bars in the dash area, the dash panel may be removed. The front roll-cage legs are to follow the "A" pillar line.

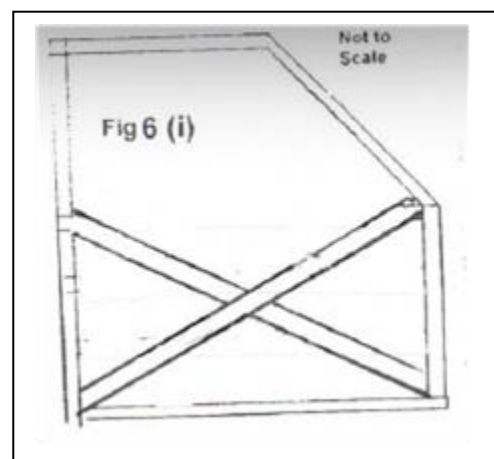
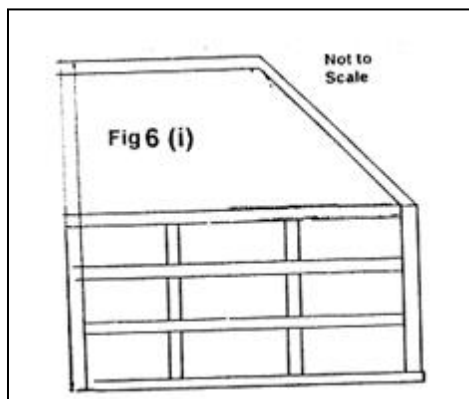

**RIGHT-HAND SIDE NASCAR DOOR BARS FOR ALL CARS.
LEFT HAND SIDE MUST HAVE A
MINIMUM OF ONE HORIZONTAL
AND ONE DIAGONAL BAR.**

**LEFT HAND SIDE NASCAR DOOR
BARS FOR FJ HOLDENS ONLY**

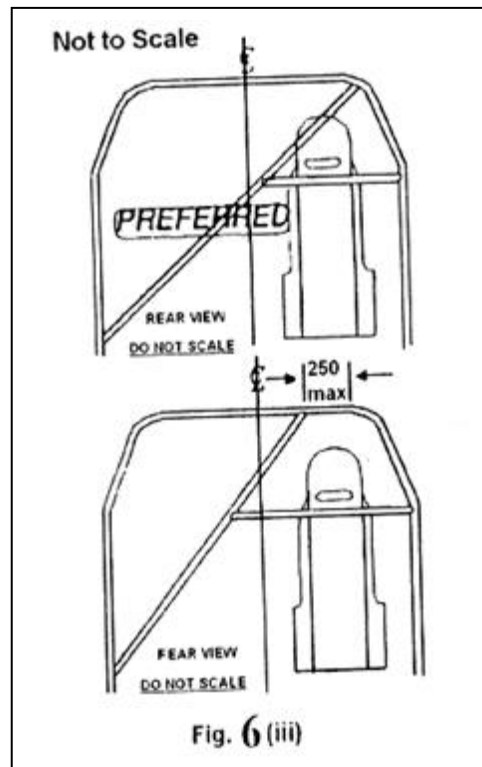
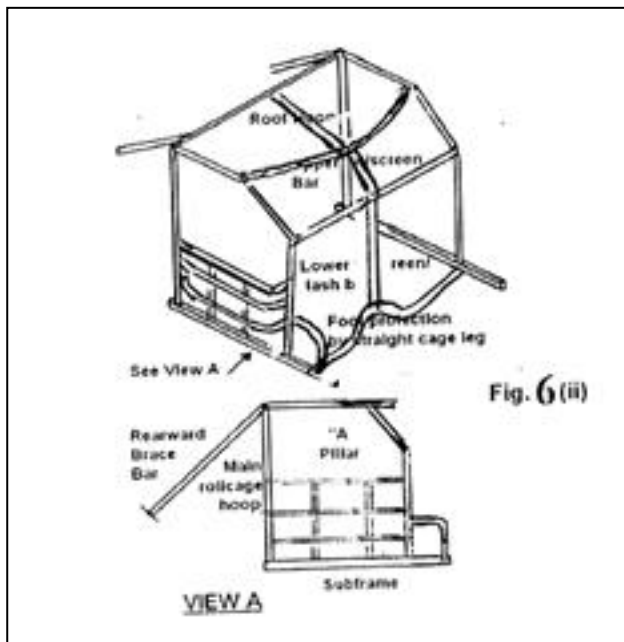

l) Sub-frame material Sizes

- a) Tubular min. 38mm x 3mm wt. CHS or 50mm x 50mm x 3mm wt. RHS
- b) Angle minimum 50mm x 50mm x 5mm
- c) A one-piece diagonal brace, min. 38mm OD x 3.0mm CHS. will be fitted in the main roll cage hoop behind the driver's head, within 250mm of the corner and down onto the left side roll cage leg. (Top right to bottom left) Fig 6 (iii).
The diagonal brace, top right to bottom left, intersects with the main diagonal brace. If a cruciform type bracing is used a minimum of 32mm OD x 30mm wt. CHS may be used.

ADDITIONAL MINIMUM BARWORK

Material size – 38mm OD x 3.0mm wt. CHS.

- a) Top windscreen bar.
- b) Lower windscreen/dash bar.
- c) Seat back support/Shoulder belt mounting bar.
- d) NASCAR Door Bars

On the driver's (right) side – three horizontal side bars, curved out to the door skin, are to be placed between the front and the rear cage legs, evenly spaced between the windowsill and the roll-cage sub-frame.

A minimum of two vertical spacer bars, evenly spaced between the front and rear roll cage legs, are to be fitted between the cage sub-frame and the top horizontal bar. The top horizontal NASCAR bar will be within 50mm of the windowsill ("NASCAR" bars in Fig 6 (II)).

FJ Holden Only – if left hand door to be operational for driver entry a crucifix is to be placed on the left side of the roll cage between the A pillar front leg and the Main Hoop – to be from window height to roll cage sub frame and be 38mmx3mm CHS. See the drawing above.

- e) Anti-Spear Plate can be segmented. To be 3mm steel or 5mm aluminum fitted to the driver's side, forward of the first uprights to the front of roll cage leg.

A minimum of one-third of the door opening is to be covered, front to back, and from the top NASCAR bar to the bottom sub frame bar.

- f) Cross Braces – A minimum of two sub-frame cross braces at the roll-cage legs, either 38mm OD x 3mm wt. CHS or 35mm x 35mm x 3mm wt. RHS.
- g) Centre roof bar, 32mm OD x 3.0mm wt. CHS.
- h) Centre windscreen bar, 25mm OD x 3.0mm wt. CHS.
- i) **Optional** – Rearward brace bars from the top rear of main hoop down onto rear sub-frame or wheel arch (approx. 45 degrees).

Must attach to the rearward side of the hoop within 100mm of the centre of the top radius, to be of 34mm CHS. May have one spreader bar as long as it is of pipe material. Maximum 34mm x 3mm brace bar must not be welded to floor/sub-frame.

- j) The mesh screen, in front of the driver, will be securely fitted to the roll cage/body. Maximum mesh size 50mm x 50mm. Minimum size 3mm. Mesh screen to cover entire area from "A" pillar to centre bar and from dash to roof bar. Windscreen mesh to be welded or clamped with metal clamps to the roll care "A" pillar and centre windscreen bar. Minimum of four clamps. Mono cars may be welded to the body.

- k) The minimum requirement for foot protection to be a bar of roll cage material. Fig. 6 (iv) Foot protection bar to be fully plated with 3mm steel or 5mm aluminum. Foot protection bar to be braced to the left to bar work.

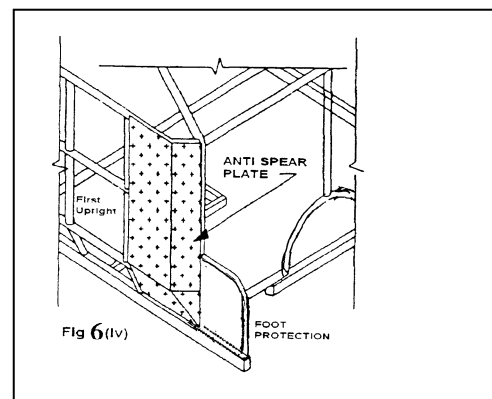

HEAD PLATE

A minimum of 50mm clearance is required between the helmet, including fresh air intakes and associated fixtures to any part of the head plate and roll cage when driver is seated and harnessed.

- a) A head plate minimum 3mm steel must extend from rear roll cage bar to top windscreen bar and from driver's side outer roof bar to centre roof bar. This plate must be securely welded to these bars with an intermittent welding procedure. No lightening of Head Plate e.g., drilling holes or removal of corners.
- b) For helmet clearance between roll cage roof/hoop bars for existing vehicles may raise head plate as per drawing below to obtain 50mm clearance.

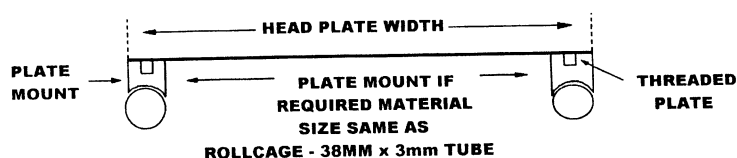

- c) Stubs are to be end capped and threaded for mounting purposes.

23. BUMPER BARS

- a) Front and rear pipe bumper bars to be fitted – maximum 38mm x 3mm CHS or 50mm x 1.6mm CHS.
- b) Pipe bumper bar to be securely attached to subframe rails.
- c) Bumper bars must follow the original contour of body and be a maximum of 50mm from inside edge at bumper and body.
- d) Bumpers remain hollow.
- e) Front and rear bumpers to have a maximum of 4 mounting points.
- f) Corner plates not permitted on top of either front or rear bumper.
- g) An over-ride bar may be fitted - 25mmx3mm OD on the top of the bumper mounted centrally and a maximum of 600mm in length and not higher than 100mm.
- h) If an original front and rear bumper is used – **no reinforcing is permitted** - it is to be attached to the sub frame of vehicle using original mounting brackets.

24. SKID RAILS – OPTIONAL

- a) Skid rails are optional
- b) Skid rails to be 25mmx25mmx3mm mild steel RHS.
- c) Skid rail to be attached to an inner skid rail of 25x25x3mm mild steel RHS – not to be attached to body panels.
- d) Skid rail to be attached to a minimum of 4 places evenly spaced using a minimum 8mm round head bolts. To be bolted within 50mm of each end
- e) Inner skid rail is to be returned to barwork at each end.
- f) Outer skid rail must have capped and 45° tapered ends.

25. REINFORCING

Strengthening of support points (e.g., spring hangers and K frames and chassis rails) accepted provided no strengthening is connected to any bumper brackets.

NO OTHER INTERNAL OR EXTERNAL REINFORCING ALLOWED

26. ENGINES

Cars must be fitted with the OEM engine block for that series.

BLOCKS

- a) All Holdens permitted to use up to and including 202 cubic inch RED motor.
- b) All Falcons and TC Cortina permitted to use up to and including 250 cubic inch LOG engine. No crossflows permitted.
- c) Maximum engine permitted in a Centura – Slant 6

HEADS

- a) All engines over 2800cc will use the cylinder head casting for the engine block type casting used. e.g., Holden 202 Red motor only can use 9 port head.
- b) All engines under 2800cc are permitted to use any OEM cylinder head available for make **block being used**.
- c) All engines must be two valves per cylinder with one only flat tappet camshaft. Exception only for Duston Rotary valve heads for Holden grey motors.
- d) Engines fitted with forced induction will be only one compressor, OEM cylinder head and a maximum capacity of 2800cc.
- e) All engines will be restricted to 4 venturis for induction system.

A total maximum capacity of 5000cc for any engine in this class.

All engines are to be mounted in the OEM position in the engine compartment.

27. CARBURETOR

- a) All engines will be restricted to 4 venturis for induction system.
- b) All cars fitted with single carburetor OEM are permitted to use a 2-barrel Holly carburetor on OEM or OEM option for engine intake manifold, with a bolt on, NOT WELDED, adaptor block that is of a maximum thickness of 1.000" (25.4mm)
- c) The use of twin or triple carburetors are permitted using OEM or aftermarket manifolds.
- d) No custom-made manifolds are permitted.
- e) The throttle system must be fitted with two separate throttle springs.

28. COOLING SYSTEM

- a) Radiator can be mounted in front of car in original position and/or in rear of cabin area.
- b) Radiators may be mounted as low as possible in the rear firewall and suitably isolated from the driver. The upper half of the window MUST NOT be obscured by the rear radiator. Cabin mounted radiators to be behind the roll cage main hoop.
- c) Radiator can be converted to cross flow or vice versa. Cabin mounted radiators must have tanks shrouded to protect the driver. Cabin mounted radiators must be completely behind the Main Roll Cage. Radiator cap to be fully shrouded from the driver for any type of radiator.
- d) Full aluminum proprietary competition radiators do not need the tanks covered.
- e) Rear Radiator Coolant pipes through the cabin area are to be on the inside of the roll cage and to be lagged or suitably covered. Connecting hoses are to be kept as short as possible and to connect to the radiator from the rear.
- f) All radiator hoses must be fabric reinforced material, plain molded hoses not permitted. Cabin mounted radiators must have BOTH tanks covered to protect driver in the event of the cap or tank blowing.
- g) All pipes in cabin area to be steel, aluminum or copper tubing securely mounted to roll cage and body.
- h) All pipes have no joints near the driver and must be suitably isolated and lagged – in cabin area.
- i) Cabin mounted radiators may have auxiliary cooling fans fitted and are to be shrouded/fitted with guards.
- j) Engine fan – Optional.
- k) Electric Fans permitted.
- l) A Lever Vent radiator cap must be fitted. Push button type caps NOT permitted.
- m) Radiator Shrouds and Air Deflectors. Cabin mounted radiators may have air deflector shrouding fitted to front of radiator no further forward than 600mm and rear of roll cage main hoop. No shrouding permitted on top of radiator. Height of shrouding to be no higher than the height of the cabin mounted radiator.
- n) Sprinkler bar or any such like device used for the provision of cold water onto the exterior of the cabin mounted radiator NOT permitted.
- o) The use of expansion filler tanks is limited, with discretion shown by the Scrutineer.

29. EXHAUST SYSTEM

- a) The use of extractors is permitted.
- b) Internally ducted exhaust system if used must vent through the body not higher than 100mm above the door sill panel, and to finish flush with the door panel.
- c) Driver to be suitably insulated from exhaust system. Insulation and firewall sheeting not to exceed 150mm above the tail shaft tunnel.
- d) Exhaust must extend past the driver in the seated position.
- e) If the exhaust system is under floor, minimum 6mm chains will be fitted to the front and the rear of the exhaust pipes and attached securely to the floor pan or sub-frame.
- f) The muffler/s must be securely attached to the vehicle.
- g) **NOISE** must be within the local requirements, recommended maximum 95 D.B.A.

30. TRANSMISSION/DRIVELINE

- a) 360° Tail shaft Loops – Steel strap minimum 40mm x 5mm FMS or 6mm chain or 6mm wire rope to be SECURELY fitted around the front and the rear of the tail-shaft within

150mm of universal joints to prevent the tail-shaft and or shafts from dropping in an event of breakage.

- b) Conversion of two-piece tail-shaft to one piece and vice versa is permitted. (Additional tail-shaft hoops required for two pieces).
- c) Scatter Shield of 3mm steel / 5mm thick aluminum x 150mm wide minimum must be fitted to the inside of the car or beneath the floor in the appropriate area to prevent injury in the event of a clutch explosion.
- d) **Differential may be upgraded to be any passenger car type differential.** No quick-change differentials permitted. All mounts and pivot points are to be in OEM position and being used.
- e) Gear boxes – to remain OEM internally and externally for car being used e.g., no Birt, Brinn, Falcon boxes etc. **All gears to be present and operational.**

31. BATTERY AND ELECTRICAL SYSTEM

- a) Battery may be in original position under bonnet or securely fastened in a steel box or marine box secured to the chassis barwork/roll cage. Plastic clamps not permitted. Steel box thickness to be no greater than 5mm absolute and relative to the battery being used.
- b) One only battery to be fitted and maximum size of N70ZZ.
- c) It is recommended that rubber covering be placed over the battery and the exposed metal of the cable terminals to reduce acid spillage, and to reduce the chance of arcing if metal contacts the battery in any incident.
- d) Suitable grommets must be fitted where electrical cables pass through metal firewalls.
- e) All electrical wiring must be mounted clear of fuel lines. No switches to be mounted through the floor.
- f) A battery isolator (“kill”) switch is **MANDATORY and** fitted in cowl panel in a central position. Method of operation to be clearly marked, with a contrasting colour, adjacent to switch. Dipper switches are NOT to be used.
- g) At the commencement of a meeting, the car must be capable of starting with starter motor.

32. STEERING

- a) **Steering may be upgraded – e.g., the steering box can be changed to rack.**
- b) Must be in sound condition. Steering joints to be split pinned or have nyloc nuts fitted.
- c) The steering wheel hub to be padded with dense resilient foam and covered.
- d) Steering quickner may be used.
- e) Quick release steering wheels mandatory.

33. BRAKES

Drum brakes may be upgraded to disc brakes. Foot operated hydraulic brake system to operate correctly on a minimum 3 wheels (only right hand front optional) and be effective at race speed.

34. SUSPENSION

- a) Original type front and rear suspension must be retained. Example – rear leaf spring must remain leaf spring – front wishbone to remain wishbone.
- b) If OEM option for make and model aftermarket / fabricated front wishbone / control arms can be used but must mount in the original mounting point/position.
- c) If OEM option for make and model aftermarket / fabricated rear trailing arms can be used but must mount in the original mounting point/position.
- d) If OEM option for make and model aftermarket / fabricated Panhard bar / watts linkage is permitted to be used in the original mounting point/position.
- e) **Suspension mounting points may be fabricated but must mount in the original point/position. No non-OEM type suspension components may be added.**

Shock absorbers

- a) Front – coil over shock absorbers are permitted to be used **and may be mounted to barwork or** in the original shock absorber mounting point/position.
- b) Rear – coil over shock absorbers are permitted to be used but must mount in the original shock absorber mounting point/position. **Coil over shock absorbers if used must be used in conjunction with original type suspension.** If a car is originally fitted with leaf springs, leaf springs must remain.

35. FRONT/REAR HUBS, AXLES AND TAIL SHAFT

- a) **Rear Axle Bearing Retaining Rings:** If using a rear axle assembly not fitted with floating axles, a new retaining ring must be fitted as a replacement for a bearing or axle. It must be an interference fit with the axle. When in place the retaining ring is to be **tack** welded to the axle using small diameter low hydrogen rods on low amperage. Failure to observe these procedures will incur a penalty especially if an axle is dislodged. Carbon fibre tail shafts are NOT permitted.
- b) **Tail Shaft Straps:** Tail shaft(s) must be fitted with 360 deg. Hoops (MIN. 40x3mm FMS) or chains or wire rope cable (MIN. 6mm) at front and rear to prevent the tail shaft dropping out in the event of a shaft or universal joint breakage. Straps must be securely mounted approximately 150mm from the universal joint and incorporate full loop through floor pan.

36. FUEL

The use of cooling systems for fuel is not allowed.

LPG or CNG is NOT permitted.

- a) Permitted fuels are PULP, ULP, E10, E85 or Methanol
- b) Blending of ethanol-based fuels with ULP or PULP fuels is NOT permitted.
- c) The introduction into the combustion chamber/s of nitro fuels and/or additives, either in solid liquid or gaseous form (e.g., nitrous oxide) by any means is expressly forbidden.

37. REPLACEMENT FUEL TANK AND FUEL SYSTEM

- a) The original type of car fuel tank must be removed.
- b) A fabricated steel tank, 50 litres Max, using Min 1mm gauge material. All joints to be welded or lapped and brazed.
- c) A fabricated aluminum tank 50 litres Max, using Min 3mm gauge material. Tig welding recommended.
- d) A certified racing Fuel Cell may be used. NO OTHER PLASTIC TANKS.
- e) All fuel tanks must have a positive seal fuel cap.
- f) A breather hose to be fitted to tank and must cover all sides of tank, i.e., 8 sides, to alleviate spillage in a rollover.
- g) A recognised Metal non-return valve can be used in a short breather hose to avoid spillage, i.e., Sigma/Toyota metal brake booster valve.
- h) Pressurised fuel tanks **are** NOT permitted.
- i) Fuel tanks to be securely mounted to rear chassis rails in a suitable cradle. The use of tags (ears) to mount fuel tanks are disallowed. Fuel tanks are to be mounted using straps attached to the cradle. Tank to be mounted as far forward as possible but remain in boot area. For ventilation of fumes and spilled fuel an area minimum 300mmx300mm below the fuel tank is to be removed. Fuel tanks not to protrude under the boot floor and must be above sub frame floor.
- j) Fuel tank to be no closer than 150mm from rear panel.
- k) Fuel tank can only be mounted between the rear chassis rails in line of sight.
- l) Fuel tank to have a protection bar of 38mm O.D. x 3mm WT minimum. Fuel tank protection bar to have a 25mm clearance from any part of the fuel tank in all directions. It is to be mounted between the rear chassis rails behind the fuel tank and be braced forward with a 25mm x 3mm minimum to the downward rear boot bars. Fuel tank protection bar to be formed from one piece and have radius formed corners.

38. FUEL LINES AND FITTINGS

- a) A flexible fuel line section must be fitted within 75mm of fuel tank and all fuel lines to be securely fixed in position.
- b) Copper, Neoprene, "Black Fuel Line" may be used. If copper pipe is used a minimum length of 75mm of flexible hose to be used at fuel tank and fuel pump. The correct fittings and screw type clamps to be used on all fuel pipes and hoses and be securely attached on top of the floor. Where fuel lines go through front and rear firewalls, lines to be suitably grommeted.
- c) Neoprene, reinforced plastic or "Black Fuel Line" may be used. OEM type Bundy steel tubing may be used through the car or under the car.
- d) Flexible fuel lines can pass through the cabin area.
- e) High pressure lines are used must use high pressure hose and fittings.
- f) The actuator or switch is to be mounted within easy reach of driver and crash crew, and clearly marked "FUEL" ON/OFF.
- g) If a return line is used, it must be fitted with a one-way valve.
- h) The fuel line must be fitted with a quick action non-leak tap, in working order, securely mounted within easy access by the hand of driver, passenger and crash crew and method of operation clearly marked. Size to be at Scrutineers discretion. Alternatively, an electronic fuel lock may be used.
- i) Fuel injection permitted.
- j) Forced induction permitted.

39. WHEELS AND TYRES

- a) Wheels must be in good condition and free from cracks.
- b) Maximum 15-inch rim permitted – maximum width 12 inch (305mm).
- c) As of 1st July 2025 – maximum rim width 7'
- d) Bead locks are permitted to be used.
- e) Balance weights to be securely fastened or taped.
- d) Safety inner tubes are permitted.
- e) Wheel studs are not to protrude further than 12mm past the outer face of the wheel nuts and to be contained within the rim so as not damage another competitor's tyre.
- f) Radial tyres and racing rubber are permitted.
- g) Any type of lubrication (grease or oil etc) is not permitted on the tyre wall. Tyre shine type cosmetic products are permitted for application to sidewalls only.
- h) Note – at some point in the future a wheel track and wheelbase measurement may be introduced.

40. IDENTIFICATION NUMBERS

- a) All vehicles must carry the correct identification roof number and car number as issued by the Club of registration.
- b) Approved car numbers are to be on each side of the car, in contrasting colours, must be easily distinguishable at a distance - minimum 400mm high and appropriate width.
- c) The roof number plate must be 300x300mm absolute x 1.6m MIN. mounted vertically to be angled from right rear to left front corner of roof panel. Colour must be white numbers on black background. Numbers to be in block font.
- d) Driver's name to be written on right hand side of the roof above the driver's door minimum 50mm high or on visor strip in letters clearly legible to officials.
- e) Registered number of the car to be displayed on rear of car in taillight area to assist with lining up on the racetrack to be minimum 100m high.

SSQ REGISTRATION DECAL TO BE PLACED IN A PROTECTED POSITION THAT CAN BE CLEARLY SEEN AT SCRUTINEERING.

41. PAINT WORK AND SIGN WRITING

- a) All paint work, sign writing and numbers to be neat, attractive and of a professional standard.
- b) Fuel tap – to be clearly marked, indicating FUEL and the positions ON/OFF.

- c) Engine Kill Switch – to be clearly and suitably marked with a contrasting colour and must be fitted in the centre of the cowl panel.
- d) Approved numbers to be displayed on each side of car (in contrasting colours and clearly distinguishable) minimum 400mm high.
- e) The roof number plate must be 300x300mm absolute x 1.6m MIN. mounted vertically. Colour must be white numbers on black background. Numbers to be in block font – minimum 250mm high.
- f) Driver's name to be written on right hand side of the car 50mm high and on visor strip in letters clearly legible to officials.
- g) The car is always to be presented in a professional manner. Race night repairs may be carried out using zip ties and race tape.